

*Roller Shades*

# MOTORIZED SHADE

Simplicity with rechargeable motor



Installation & Care Instructions

152709 C  
4/26/2017

## GETTING STARTED

**IMPORTANT:** The remote control has **not** been linked to the shades. Install all shades prior to linking the remote.

A few simple tools are required:

- Measuring tape
- Power drill, drill bits
- 1/4" Hex head and/or Phillips driver bit
- Pencil

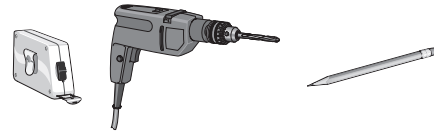

Additional fasteners other than those sent with your shade may be required depending on the mounting surface. Wallboard and plaster require the use of anchors such as expansion or toggle bolts. Brick, tile or stone need special plugs and drill bits. Remember to always pre-drill holes in wood to avoid splitting.

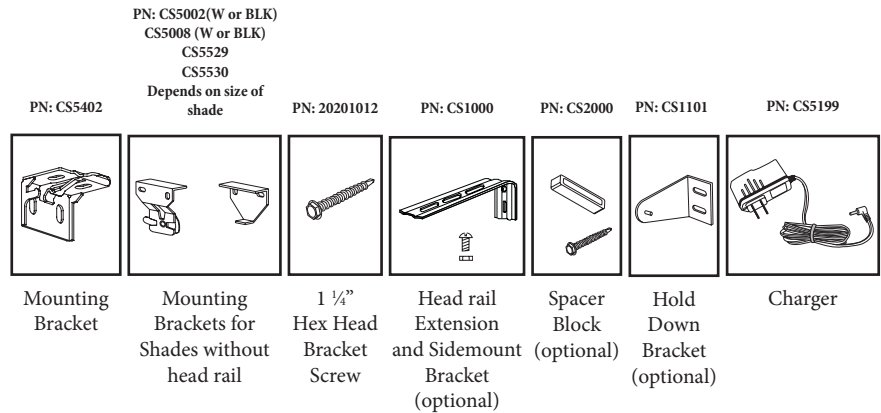

## STEP 1: BRACKET INSTALLATION

### SHADES WITH HEAD RAIL

Shades are shipped with the required number of brackets for proper installation. End brackets should be located approximately 3" from either end. Depending on the width of the shade, additional brackets may be necessary, evenly spaced between the two end brackets.

Using the installation bracket as a template, measure to the edge of the bracket and mark the hole locations with a pencil for drilling.

Brackets must be in line and level. Shim brackets on inside mounts if necessary. The head rail must be level for the shade to operate properly.

Shade Width	# of Brackets
Up to 40"	2
>40" - 72"	3
>72" - 84"	4
>84" and up	5

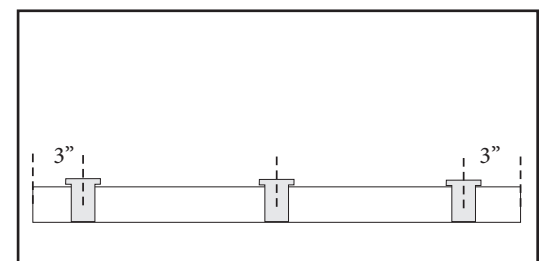
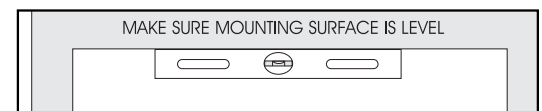

## INSIDE MOUNT

The minimum mounting depth for an inside mount is 1".

A minimum of 3 3/4" is needed to fully recess the shade.

Make sure the brackets are level and aligned.

Attach using two screws.

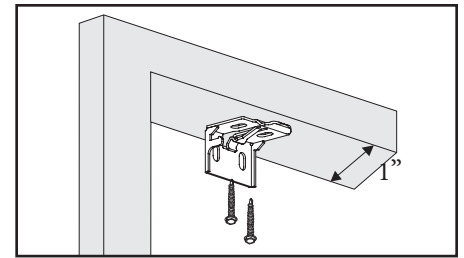

**Inside Mount**

Shallow Mount - Minimum 1" surface

Flush Mount - Minimum 3 3/4" surface

## OUTSIDE MOUNT

The minimum mounting height for outside mounted shades is 1".

Make sure the brackets are level and aligned.

Attach using two screws.

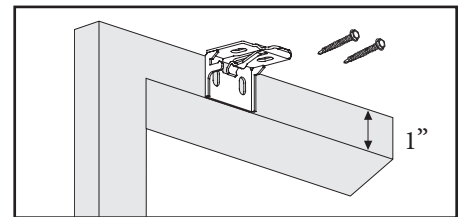

**Outside Mount**

Minimum 1" surface

## SPACER BLOCKS (OPTIONAL)

Each spacer block projects brackets 3/8" away from mounting surface.

Make sure the brackets are level and aligned.

Attach using two screws. Screws should be long enough to secure the bracket to the mounting surface.

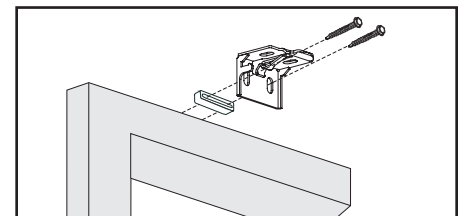

**Outside Mount with Spacer Blocks**

## EXTENSION BRACKETS (OPTIONAL)

Optional extension brackets are used to project the back of the shade up to 2 1/2" from the mounting surface.

Attach the mounting bracket to the extension bracket with the nut and bolt provided.

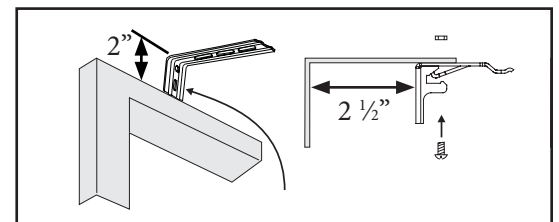

**Outside Mount with Extension Brackets**

Minimum 2" surface

## SIDE MOUNT (OPTIONAL)

Measure from window sill up to desired mounting position on each side of the window frame. Mark position.

Mount side mount brackets on each side of window frame as shown. Make sure to confirm the head rail will sit perfectly level.

Once side mount brackets are installed and properly positioned, attach the mounting brackets using the nuts and bolts provided.

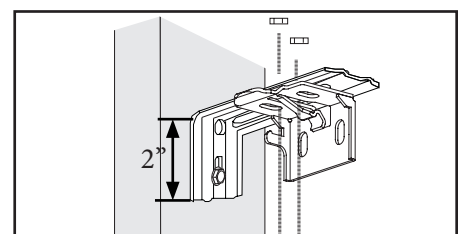

**Side Mount**

Minimum 2" surface

## SHADES WITH NO HEAD RAIL

The installation brackets are always mounted so that the inner surfaces face each other.

Brackets must be in line and level. Shim brackets on inside mounts if necessary. The head rail must be level for the shade to operate properly.

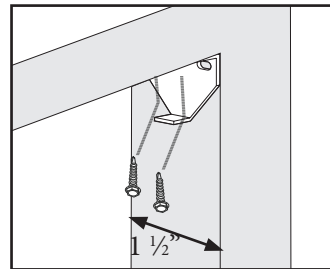
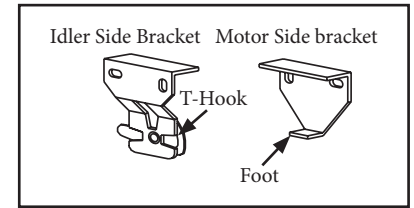

**Inside Mount**  
Minimum 1 1/2" surface

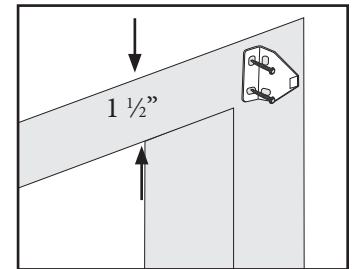

**Outside Mount**  
Minimum 1 1/2" surface

## STEP 2: SHADE INSTALLATION

### SHADES WITH HEAD RAIL

Center the shade in the window opening and push the head rail into the mounting brackets as shown.

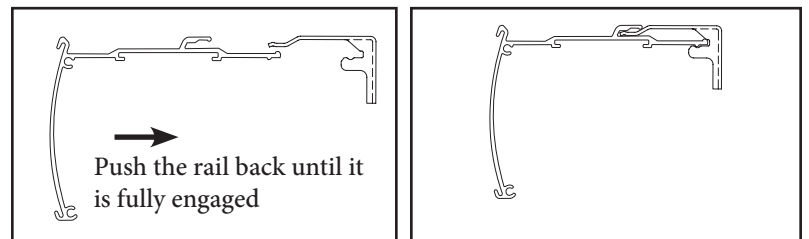

### SHADES WITH NO HEAD RAIL

Once the brackets are secured and level, the fabric roll can be inserted. Make sure your hands are clean to avoid soiling the fabric.

Insert the foot of the motor-side bracket into the slotted center hole of the motor end of the fabric roll. The wire should be positioned so that it goes up on an inside mount or back on an outside mount. This will provide easy access to the setting button.

Set the post of the idler end into the V of the support bracket. Rotate the T-hook on the support bracket to lock in the post and secure the fabric roll.

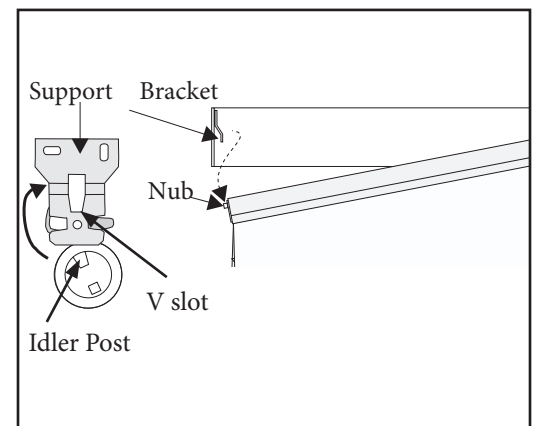

## STEP 3: LINK REMOTE

The remote control has multiple channels. Before linking the remote, determine which shade(s) you want on which channel. The standard remote has 5 channels, the remote with timer has 6 channels. All shades linked to a remote will also automatically be programmed to the “ALL” channel.

Remove plastic film from the front of the remote.

If battery is not already installed in the remote follow the instructions on page 12.

**If using a timer remote, Turn the remote on using the power button on the right side of the remote. Then, tap the clock button until you see “MANUAL” in the display.**

1. Press the **SETTING** button on the motor until the shade jogs once. Release the button immediately after the first jog - this should not be more than 3 seconds.

2. Repeat this step for all shades that will be controlled by the same channel.

3. Select the channel that you want to program using the **CHANNEL** selector button.

4. Press and hold the **CONFIRM** button until the shade(s) jogs once. The shade is now linked to the remote.

5. Repeat steps 1-4 to program the rest of the channels.

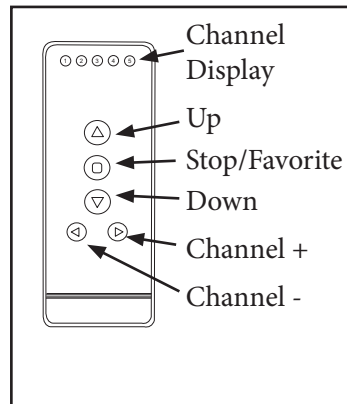
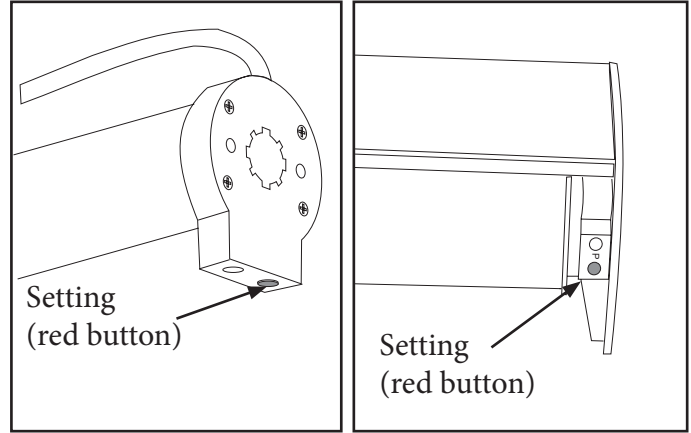

Standard Remote (front)

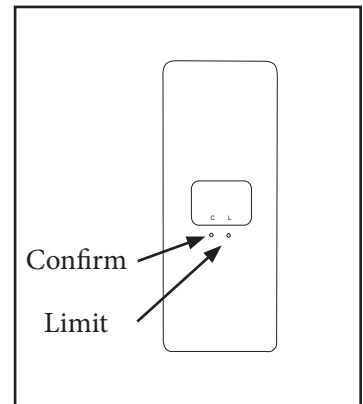

Standard Remote (back)

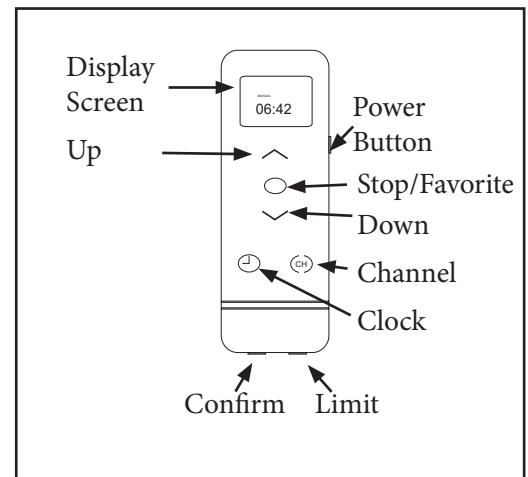

Timer Remote

## OPERATION

### STANDARD REMOTE

Select the desired channel with the **CHANNEL** buttons. The channel indicator light will illuminate the channel that is on. If all 5 lights are lit, the remote will control all 5 channels at once.

Tapping the **UP** or **DOWN** buttons for less than 2 seconds will move the shade in short steps. Holding the **UP** or **DOWN** buttons down for more than 2 seconds before releasing will operate the shade in the faster standard speed.

Press the **UP** or **DOWN** buttons to raise or lower the shade.

Press the **STOP** button to stop the shade anywhere along the travel.

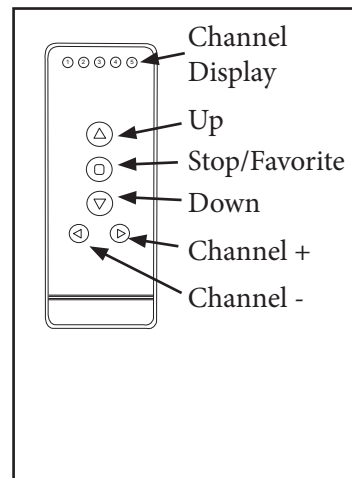

Standard Remote (front)

### TIMER REMOTE

Shades can be manually operated while in manual mode. Tap the clock button until you see “MANUAL” in the display.

Select the desired channel with the **CHANNEL** buttons. The channel will show in the display screen. If all 6 channel numbers are shown, the remote will control all 6 channels at once.

Press the **UP** or **DOWN** buttons to raise or lower the shade.

Press the **STOP** button to stop the shade anywhere along the travel.

Note: The timer remote does not have fine adjustment capability.

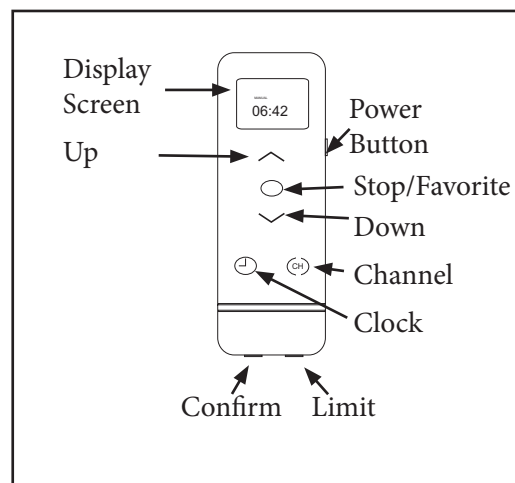

Timer Remote



Timer Remote Display Screen

## ADJUST MOTOR LIMITS (IF DESIRED)

If using a timer remote, tap the clock button until you see “MANUAL” in the display.

The lower and upper limits have been set at the factory. If you need to make adjustments to the limits, follow the instructions below.

Please Note: When clearing the factory set limits, both the upper and lower limits will need to be reset.

Use the **CHANNEL** buttons to select the channel for the shade that needs to be adjusted. Then follow the directions below.

When adjusting one shade, the other shades on that channel need to be temporarily unlinked from the remote.

To unlink a shade, press and hold the red **SETTING** button on the motor until it completes one jog - jog/ jog cycle and then release the **SETTING** button. Repeat for all other shades on that channel.

Follow the limit setting instructions below and then relink “turned off” shades by following the steps in section 3 LINK REMOTE found on page 4.

### LOWER LIMIT

Hold the **LIMIT** button until the shade stops jogging.

Use the **DOWN** button to lower the shade. Press stop when the shade is near the desired lower limit.

Use the **UP** and **DOWN** buttons to adjust the length more accurately.

Hold the **CONFIRM** button until the shade jogs. This locks in the lower limit.

### UPPER LIMIT

Use the **UP** button to raise the shade. Press stop when the shade is near the desired upper limit.

Use the **UP** and **DOWN** buttons to adjust the upper limit more accurately.

Hold the **CONFIRM** button until the shade jogs. This locks in the upper limit.

**Note:** If you also desire to set a favorite position you should do so prior to relinking other shades on that channel. See the next page for setting favorites.

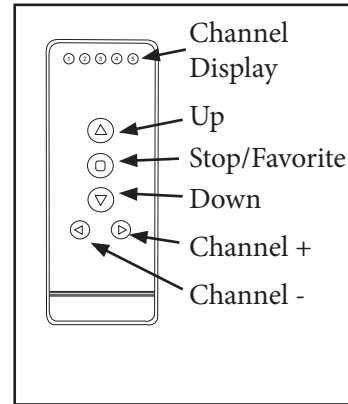

Standard Remote (front)

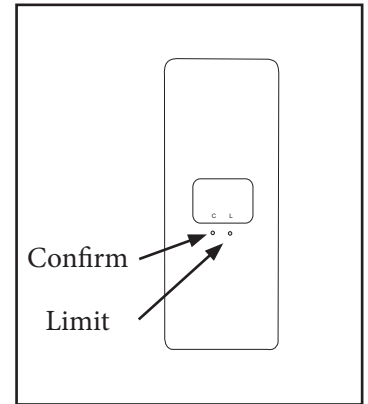

Standard Remote (back)

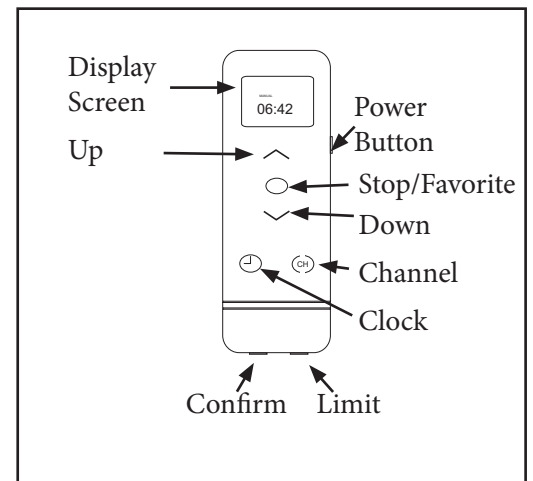

Timer Remote

## FAVORITE POSITION

When adding a favorite position to one shade, the other shades on that channel need to be temporarily unlinked from the remote.

To unlink a shade, press and hold the **SETTING** button until it completes one jog - jog/jog cycle and then release the **SETTING** button. Repeat for all other shades on that channel.

### SETTING A FAVORITE POSITION

Use the **UP** or **DOWN** buttons to position the shade at the desired “favorite” position. While holding the **LIMIT** button, quickly press and hold the **UP** button. Release both buttons when the shade jogs.

When complete, relink “turned off” shades by following the steps in section 3 LINK REMOTE found on page 4.

### USING A FAVORITE POSITION

With the shade at either the upper or lower limit, simply press the **STOP/FAVORITE** button to bring the shade to the “favorite” position. To go to the “favorite” position from any other location, make sure the shade has been stopped for at least three seconds before pressing the **STOP/FAVORITE** button.

### CHANGING A FAVORITE POSITION

Unlink all other shades on the same channel before changing/erasing the favorite position.

Use the **UP** or **DOWN** buttons to position the shade at the desired “favorite” position. While holding the **LIMIT** button, quickly press and hold the **UP** button. Release both buttons when the shade jogs.

To erase a “favorite” position, bring the shade to the **upper** limit. Press and hold the **LIMIT** button on the back of the remote, then press and hold the **UP** button. Release both buttons when the shade jogs.

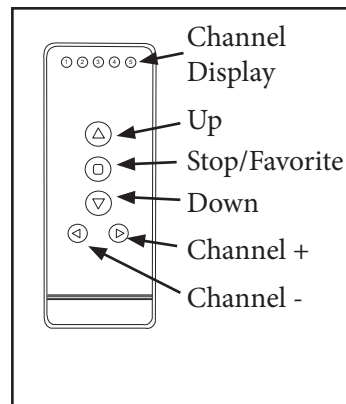
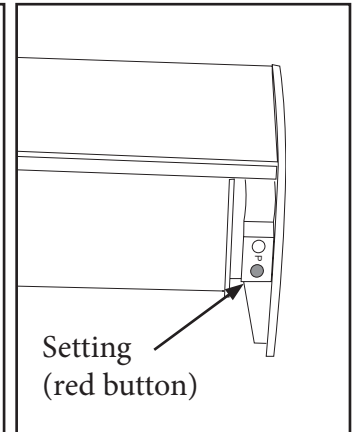
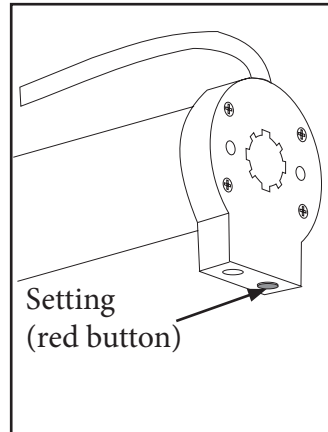

Standard Remote (front)

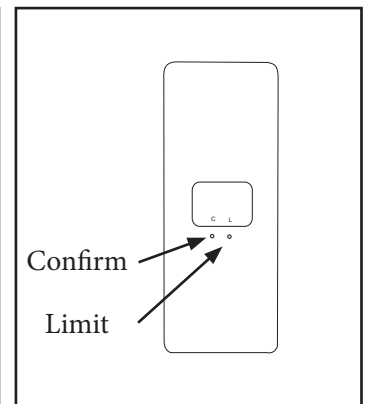

Standard Remote (back)

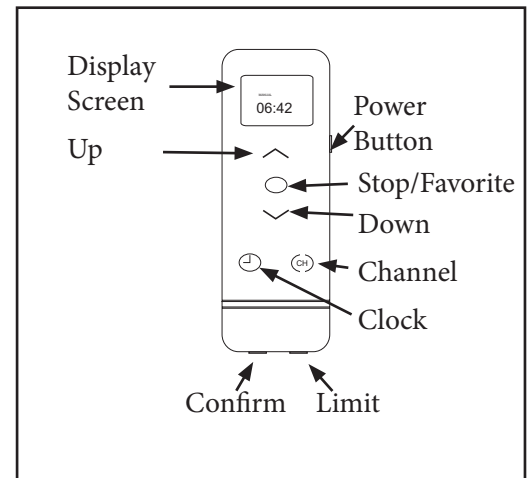

Timer Remote



## ADVANCED PROGRAMMING

### REPLACE ORIGINAL REMOTE, ADD ADDITIONAL REMOTE OR ADD SHADE TO AN ADDITIONAL CHANNEL

1. Press the **SETTING** button on the motor until the shade jogs once. Release the button immediately after the first jog - this should not be more than 3 seconds.
2. Repeat this step for all shades that will be controlled by a single channel.
3. Select the channel that you want to program using the **CHANNEL** selector button.
4. Press and hold the **CONFIRM** button until the shade(s) jogs once.
5. Repeat steps 1-4 to program the rest of the channels on a multi-channel remote.

### REMOVE A SHADE FROM A REMOTE OR CHANNEL AND LINK IT TO A DIFFERENT REMOTE OR CHANNEL

1. Press and hold the **SETTING** until it completes one jog - jog/jog cycle.
2. Release the "Setting" button. The original remote or channels have been unlinked.

### Link the motor to the new remote or channel

1. Follow the steps for replacing the remote above.

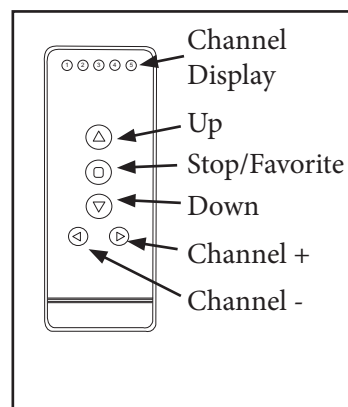
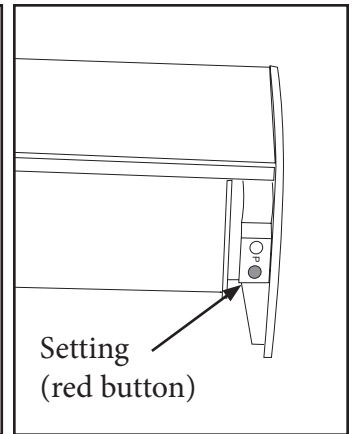
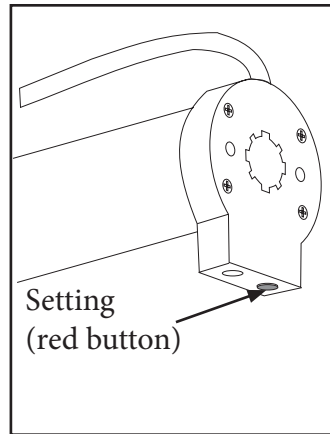

Standard Remote (front)

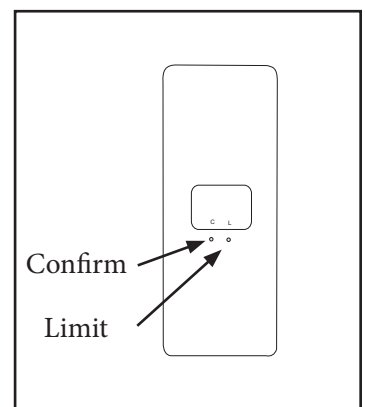

Standard Remote (back)

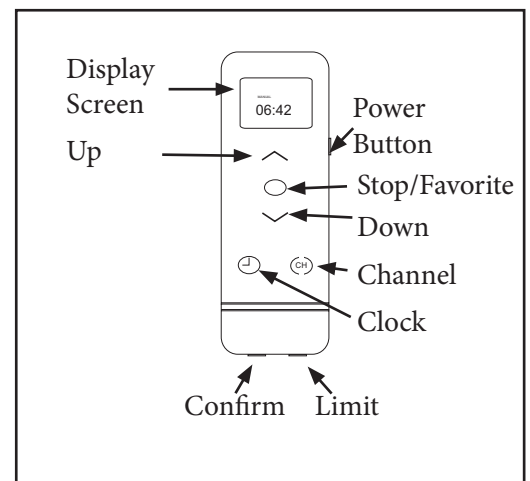

Timer Remote

# PROGRAMMING TIMER REMOTE

## SETTING CLOCK

Use the power button to turn on the remote.

Tap the **CLOCK** button until you see “MANUAL” in the display.

Push and hold the **LIMIT** button. While holding the **LIMIT** button, push the **CLOCK** button for 3 seconds and release. The hour digits will flash.

Use the **UP** and **DOWN** buttons to set the current hour. **NOTE:** Time is in 24 hour format (military time). For example: 1:00 PM will be displayed as 13:00.

Press **CHANNEL** button to confirm hour and advance to minutes.

Use the **UP** and **DOWN** buttons to set the current minute.

Press **CHANNEL** button to confirm minute and advance to day.

Use the **UP** and **DOWN** buttons to set the current day.

Hold the **CLOCK** button for 3 seconds. Display will flash and then display the current time and day.

## SETTING TIMER SCHEDULES

The timer remote allows up to 18 different timer schedules. Each timer schedule can be set for multiple channels and days, but only one function can happen at each time.

Use the power button to turn on the remote.

Tap the **CLOCK** button until you see “AUTO” in the display.

While holding the **LIMIT** button, push the **CLOCK** button for 3 seconds and release. The time will flash, then display “NO 1” and the flash “FF:FF”. If you want to set a different timer schedule press **CLOCK** for 1 second to scroll through the schedules (NO 1, NO 2, NO 3 etc.). Unprogrammed schedules will display FF:FF.

Press **STOP** button and the channel number display along the bottom of the screen will flash.

Use the **STOP** button to select the channel and move on to the next one. Use the **UP** arrow to skip a channel and the **DOWN** arrow to back up. You must press **STOP** for each channel that you want to select. If the channel is still flashing, it has not been selected.

Press **CHANNEL** button to confirm channels and advance to day selection.

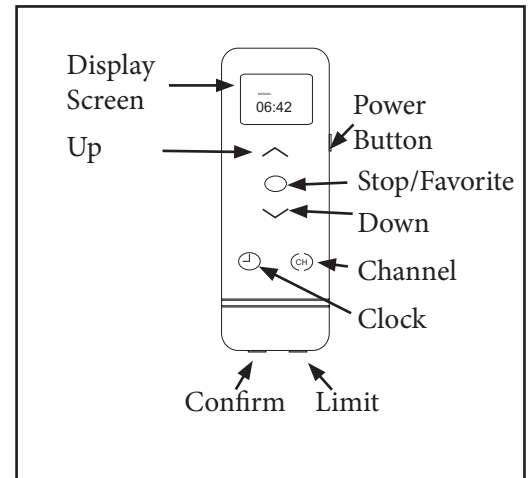

Timer Remote

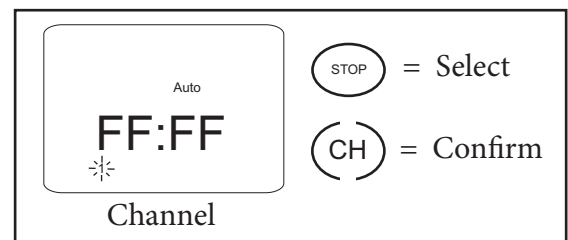

Use the **STOP** button to select the day and move on to the next one. Use the **UP** arrow to skip a channel and the **DOWN** arrow to back up. You must press **STOP** for each day that you want to select. If the day is still flashing, it has not been selected.

Press **CHANNEL** button to confirm days and advance to hour selection.

Use the **UP** and **DOWN** buttons to set the hour. **NOTE:** Time is in 24 hour format (military time). For example: 1:00 PM will be displayed as 13:00.

Press **STOP** button to confirm hour and advance to minutes.

Use the **UP** and **DOWN** buttons to set the minutes.

Press **STOP** button to confirm minutes and advance to shade operation.

Shade operation symbols are to the right of the time. Use the **UP** and **DOWN** buttons to select the operation. ▲ will raise the shade, ▼ will lower the shade, ◆ will bring the shade to the favorite position.

Press **STOP** button to confirm operation.

Push the **CLOCK** button for 3 seconds and release. The display will flash to confirm settings are saved and advance to the next schedule. Repeat the steps above for each desired schedule.

**When finished turn the power off to exit the set up mode.**

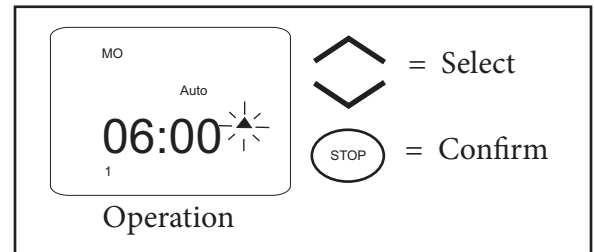
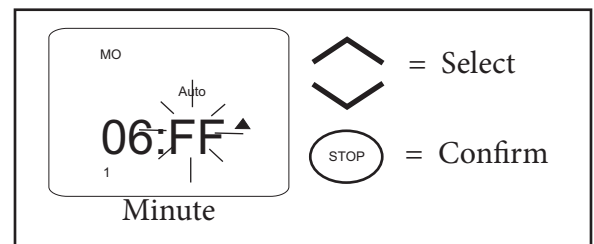
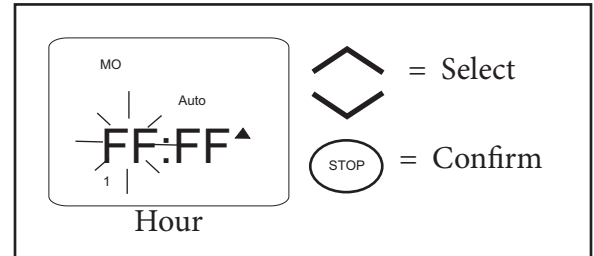
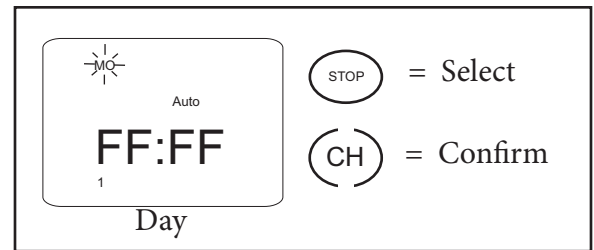

## IMPORTANT NOTES

- **Remote must be in “AUTO” mode for the set schedules to operate.** To return to “MANUAL” mode, tap the **CLOCK** button.
- When remote is in Auto mode, the display will alternate between the current time/day and the time/day/channel for the next upcoming schedule.
- To disable a schedule, simply reset the scheduled time to FF:FF.

## SAMPLE SCHEDULE

NO 1: CH1 & CH2, MO TU WE TH FR, 6:00, ▲

NO 2: CH1 & CH2, MO TU WE TH FR, 21:00, ▼

NO 3: CH1 & CH2, SA SU, 9:00, ▲

NO 4: CH1 & CH2, SA SU, 22:00, ▼

NO 5: CH3, MO TU WE TH FR SA SU, 10:00, ◆

NO 6: CH3, MO TU WE TH FR SA SU, 21:00, ▼

## SKEW ADJUSTMENT (IF NECESSARY)

If the shade does not raise evenly, first make sure the mounting brackets are mounted level with each other.

If the shade is level and it still skews, roll the shade all the way down. Prepare a strip of masking tape approximately 5" long.

On the side of the shade opposite of the skewing direction, and as close to the end of the roller as possible, apply the tape with the sticky side facing the fabric. The tape should be placed on the back of the roller, out of sight.

Roll the shade up and check for skewing. If the shade is still skewing, add another strip of tape on top of the first one. If the shade is now skewing in the opposite direction, tear off about 1" of tape from the last strip installed.

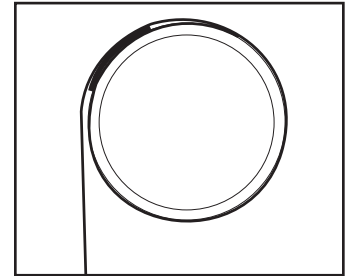
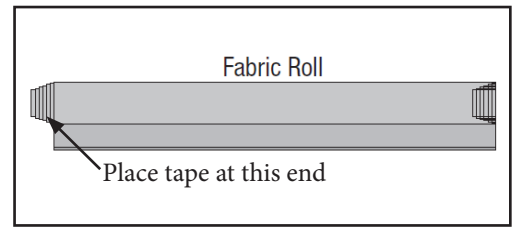

## HOLD DOWN BRACKETS (OPTIONAL)

Optional hold down brackets are mounted with the supplied screws.

With the shade at its proper drop, place the pin of each hold down into the hole in each end cap and mark the screw holes.

Make sure the pins are level and aligned.

Raise the shade, then screw the hold down bracket into the mounting surface.

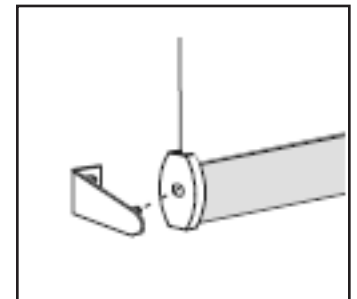

## CHARGING THE MOTOR

When the shade begins to operate slower than normal it is time to charge the motor.

Plug the 8.4v charger into the port on the motor.

Plug the charger into an electrical outlet.

A red light on the charger indicates that the motor is charging.

To fully charge the batteries, allow the batteries to charge for at least 1 hour after the light on the charger turns green.

A typical charge cycle can take between 4-6 hours.

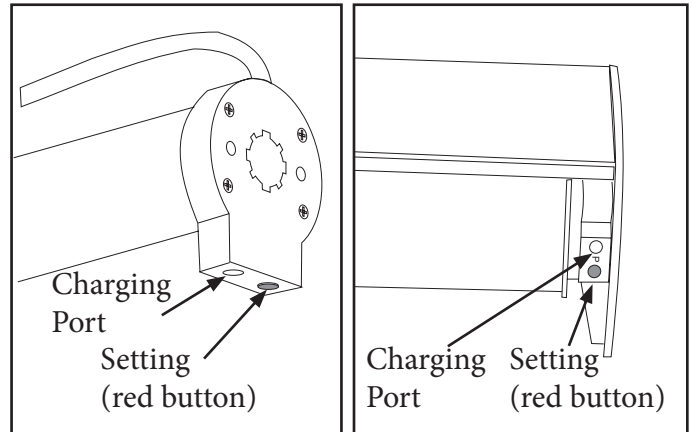

## REPLACING THE BATTERY IN THE REMOTE

### STANDARD REMOTE

Remove the battery tray from the remote by inserting a fingernail into the indentation on the back of the remote. To avoid the battery falling out of the remote, remove the tray while the remote is face up.

Insert the new battery (CR2430 lithium) into the battery tray so that the writing is facing up (positive up) when the remote is face up. Slide the tray back into the remote.

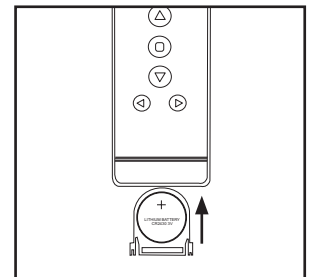
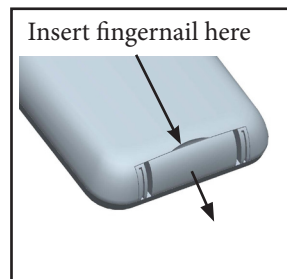

Standard Remote

### TIMER REMOTE

Slide the back of the remote down and then lift off the back cover.

Insert the new battery (CR2450 lithium) into the battery compartment so that the writing is facing up (positive up) when the remote is face down.

Replace the back cover on the remote.

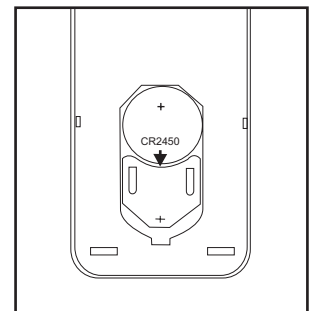
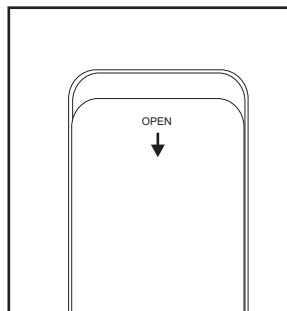

Timer Remote

## SHADE REMOVAL

If you need to remove your shade, follow the instructions below.

Partially lower the shade and insert a flat head screwdriver as shown.

Twist the screwdriver until the head rail disengages from the bracket.

As you release the brackets, support the head rail to keep it from falling.

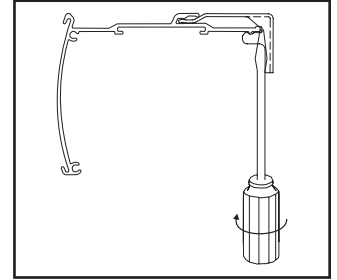

## CLEANING AND CARE

The shade fabric is easy to care for. Regular dusting with a feather duster or vacuum cleaner brush is recommended. Most stains can be blotted with a damp sponge and mild detergent. Before using anything stronger than mild detergent and lukewarm water, test an unobtrusive corner of the shade. If you have any questions, call your dealer for advice.

## TROUBLE SHOOTING

PROBLEM	SOLUTION
The motor does not work or runs slow	Recharge motor
The motor continues to run in one direction	The limit setting was unsuccessful and needs to be reset
The indicator light on the remote does not shine or the remote-controlling range becomes shorter	Replace the battery in the remote (CR2430 for standard remote, CR2450 for timer remote)